

TECHNICAL INFORMATION

<input type="checkbox"/> Valve functions	270
<input type="checkbox"/> Operating mechanism.	271
<input type="checkbox"/> Valve sizing	272
<input type="checkbox"/> Electrical parameters	273
<input type="checkbox"/> Manual overrides.	274
<input type="checkbox"/> GEM-SOL Special assembly procedures	274
<input type="checkbox"/> GEM-SOL Elastomer materials	275
<input type="checkbox"/> Flow charts for liquids & gases.	276
<input type="checkbox"/> Operation driver for latch coils	278
<input type="checkbox"/> Conduits sizing	279
<input type="checkbox"/> Long distance operators charts	280

TECHNICAL INFORMATION

Valve functions

Two way valves have one orifice and two ports : one inlet and one outlet. They are available with the following functions :

- Normally Closed (NC) Fig. 1 - valve is closed for flow through the valve when the coil is de-energized.
- Normally Open (NO) Fig. 2 - valve is open for flow through the valve when the coil is de-energized.

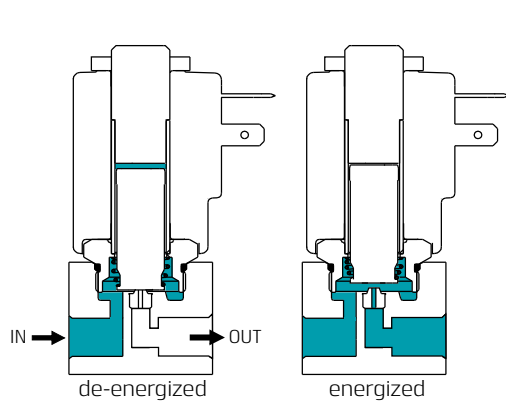

Fig. 1

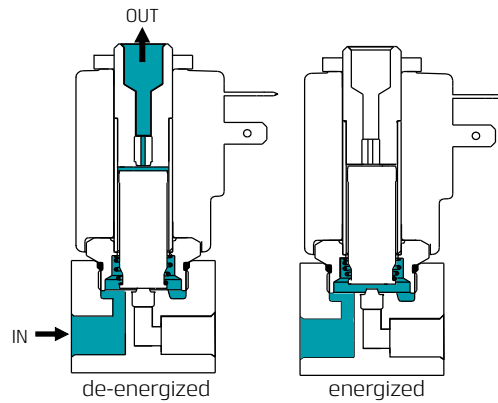

Fig. 2

Three way valves have two orifice and three ports : inlet, outlet and exhaust. They are available with the following functions :

- Normally Closed (NC) Fig. 3 - no flow from inlet port, flow is from outlet port to the exhaust.
- Normally Open (NO) Fig. 4 - flow from inlet port, no flow from the exhaust port.

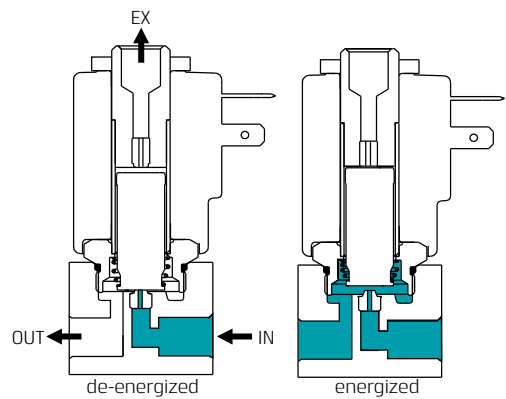

Fig. 3

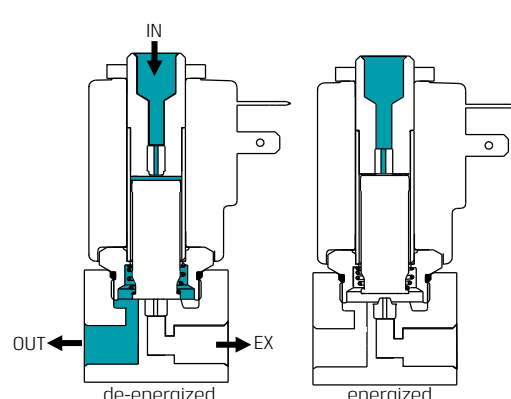

Fig. 4

Also available are the following non-standard functions : Divertor Fig. 5 - one inlet pressure with two outlets, one outlet is NO and the other NC. Selector Fig. 6 - two inlet pressures, one inlet is NO and the other NC.

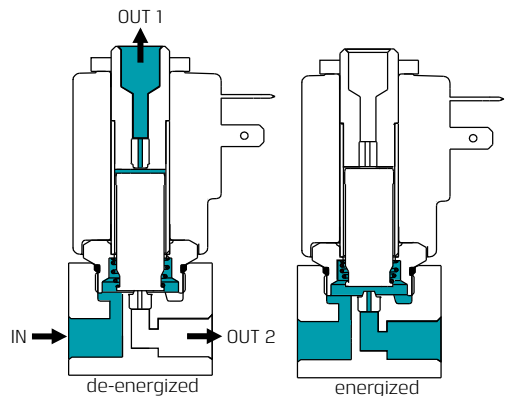

Fig. 5

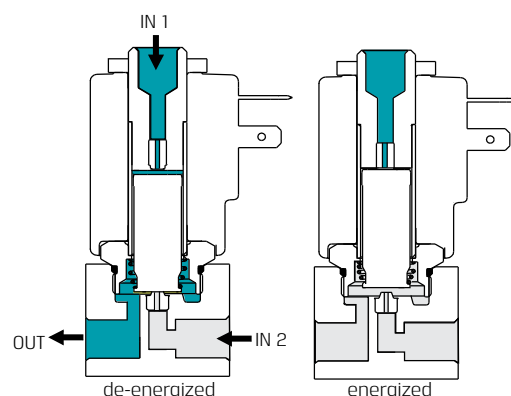

Fig. 6

Operating mechanism

A solenoid valve is a combination of two functional units :

- A solenoid (electromagnet) with a moving core (plunger).
- A valve body containing the right orifices and seals mechanism.

The plunger in a solenoid valve moves and changes the flow direction when a current is supplied to the electromagnet.

There are two basic types of Baccara GEM-SOL valves :

Direct operated solenoid valves

When the solenoid is energized in a direct acting valve, the plunger moves and directly acts on the valve disc to open, close or change the flow direction. Direct acting valves' performance depends directly on the orifice pressure and the magnetic power. The increase of line pressure or the orifice size requires more power from the electromagnet.

Pilot operated solenoid valves

These valves are recommended for applications where high flow at high pressure is required. A pilot chamber is used which is controlled by a direct acting solenoid valve. The movement of the plunger changes the pressure in the pilot chamber. When there is pressure in the pilot chamber the valve is closed. GEM-SOL pilot valves are equipped with diaphragm, according to the valve function.

- Two way valves have a bleeding passage in the diaphragm, through which the pilot pressure flows into the pilot chamber; and one orifice to release the pressure when the solenoid is energized.
- Three way valves have a three way pilot solenoid to control the pilot chamber pressure.
- Pilot operated valves require a minimum operating pressure.

Zero differential valves

We also manufacture a two way pilot operated valve which works without differential pressure. For this type of valve, a mechanical spring helps to lift the diaphragm.

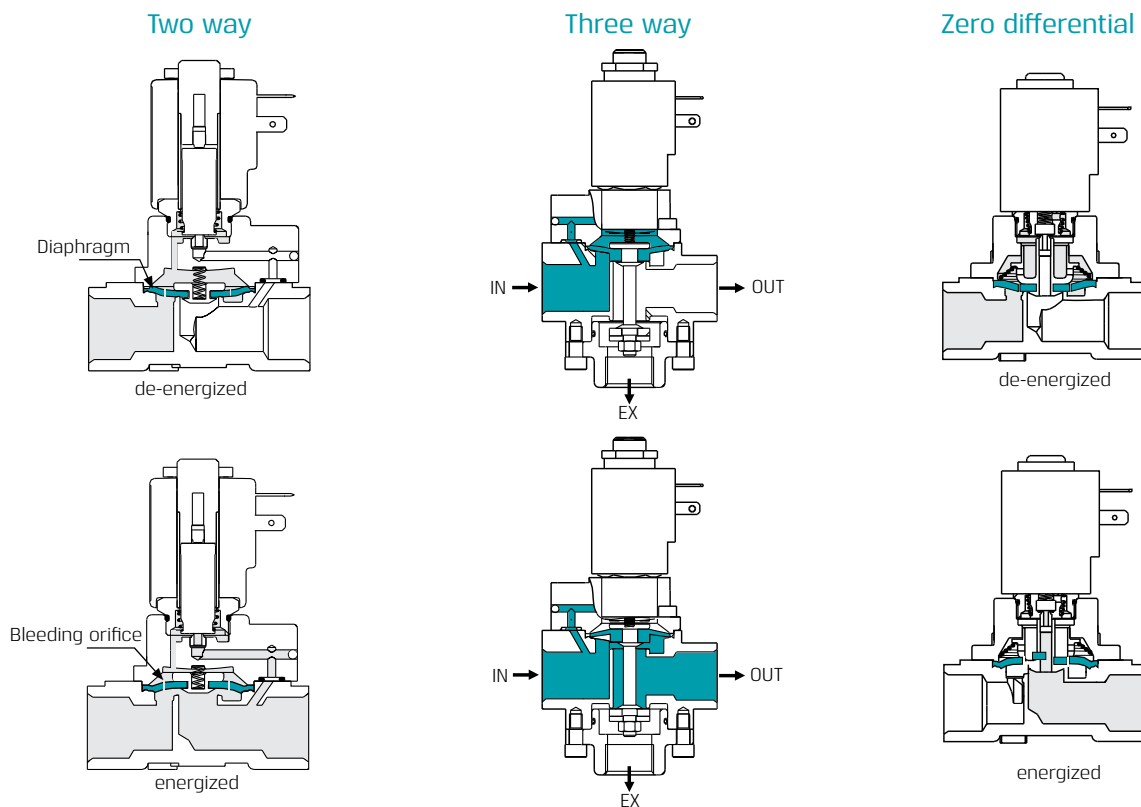

TECHNICAL INFORMATION

Valve sizing

General

It is not recommended to select a solenoid valve according to its pipe connection port or its orifice size. The valve selection depends on the knowledge of the following factors:

pressure range minimum and maximum, differential pressure, minimum and maximum flow rate, the specific gravity of the fluid, temperature, viscosity, etc.

Pressure

The pressure is generally measured above the atmospheric pressure and is expressed in kg/cm² or bars of relative pressure.

The value of pressure terms in this catalog corresponds to the relative pressure.

Pressure drop ΔP

This is the difference of pressure between the upstream P1 and the downstream P2 of the valve when it is crossed by the fluid.

Differential pressure

Minimum - maximum

This is the minimum or maximum difference of pressure between the upstream P1 and the downstream P2 which secures perfect functioning of the device. Only a pilot operated solenoid valve requires the minimum differential pressure to operate.

Flow - the flow factor Kv (Cv)

The flow of a solenoid valve is the quantity of fluid per time units crossing the valve under certain conditions. It is this factor which determines its size. To obtain a simpler method of calculation and comparison between the various types of valves, all variables permitting the calculation of the flow have been reduced to a common denominator : the flow factor Kv (without units). The Kv factor can be determined by the flow chart or by calculation. When the Kv factor is determined, select the solenoid valve which has the equivalent flow factor. The flow factor values given in this catalog have been set up according to the following method :

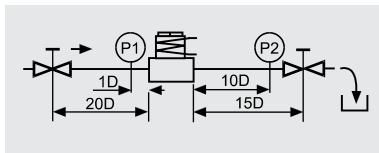

Fluid is water, specific gravity 1 kg/dm³ the pressure drop P1, P2 is 1Kg/cm² in a way that the Kv is equal to the flow in liter/min.

$$Q = K_v \sqrt{\frac{\Delta P}{\gamma}} \quad K_v = Q \sqrt{\frac{\gamma}{\Delta P}}$$

When several valves are mounted in series, the resulting flow factor is equal to :

$$\frac{1}{K_{v_{Tot}}^2} = \frac{1}{K_{v_1}^2} + \frac{1}{K_{v_2}^2} + \frac{1}{K_{v_3}^2} + \dots + \frac{1}{K_{v_n}^2}$$

When several valves are mounted in parallel, the resulting flow factor is equal to :

$$K_{v_{Tot}} = K_{v_1} + K_{v_2} + K_{v_3} + \dots + K_{v_n}$$

Unit conversion
 Kv = flow factor (decimal units)
 to convert
 CV(USA) = 0.070Kv
 f(UK) = 0.0585Kv
 Kv = 14.28 Cv (USA)
 Kv = 17.11 f (UK)

Viscosity

Practically, the flow Kv is identical for a valve crossed by water or a medium having up to 3°E viscosity. The flow/pressure characteristic is effected above this limit. It is necessary to consider factor above 3°E - the flow factor Kv will be :

$$K_{v_x} = K_{v_{water}} \cdot C$$

$$C = \frac{\delta \sqrt{K_v}}{200 \cdot Q} + 1$$

δ = kinematic viscosity (in centistokes) of the fluid

Q = flow in liter/min

Kv = flow factor given in catalog

This calculation leads to a choice of a valve with a higher flow factor value than the one which would have been chosen for a fluid having a viscosity of 3°E.

Temperature

The limits of temperature of use of a solenoid valve depend essentially upon the nature of the discs and the design of the coil. The temperature developed in a solenoid valve is a function of the electrical characteristics of the coil, the duty cycle, the fluid and ambient temperatures. These parameters determine the "temperature of use".

For each type of solenoid valve, the temperature range is given in the technical data, however these figures are only a general guide. If temperature of use might extend the given limits, please contact our technical sales department.

Response time

The response time of a solenoid valve is the lapse of time between the electric signal and the outlet of fluid signal. The response time is effected by the following parameters:

Valve function, operating mode, orifice size, inlet pressure and pressure differential, fluid, temperature and coil characteristics.

The C.E.T.O.P defines the test of conditions as follows:

Test pressure : air at 6Kg/cm² - 85 PSI

Ambient temperature : 20° C - 68° F

Response time at energizing

Response time at energizing of the solenoid and until the outlet pressure reaches 90% of the test pressure.

Response time at de-energizing

Lapse of time between de-energizing of the solenoid and until the pressure outlet drops to 10% of the test pressure, see schemas of measure method and resulting curves for AC and DC current.

Average response time for GEM-SOL valves can be assumed as follows:

- Direct acting solenoids 16 to 36 ms for complete cycle.
- Large direct acting solenoids 40 to 80 ms for complete cycle.
- Pilot operated valve 20 to 80 ms for complete cycle.

Cycling rate

The cycling rate of a solenoid depends directly on its response time.

It is the number of cycles per minutes calculated for continuous operation. The valve should not be reversed at less than 90% or above 10% at discharging of reference pressure.

$$\text{Cycles/Minutes} = \frac{60 \text{ sec}}{R_e + R_d}$$

R_e = response time at energizing (sec)
 R_d = response time at de-energizing (sec)

The cycling rate is the maximum possible cycles per minute of the solenoid valve. It varies when the valve is mounted in a circuit and depends then upon the installation pressure drop.

Electrical parameters

The following parameters define a solenoid :

Tension (V) : volts
 Frequency : 50 Hz, 60 Hz direct current etc.
 Power consumption (w) : watts (VA) volt ampere

Intensity (A) : ampere at inrush holding
 Resistance (R) : ohms
 Impedance (Z) : ohms
 Max. temperature of the coil when continuously energized.

Alternating current

$$U=Z \cdot I \quad I=\frac{U}{Z} \quad P = U \cdot I \cos \varphi \text{ (Watt)}$$

$$P = U \cdot I \text{ (VA)}$$

$$\cos \varphi = \frac{R}{Z}$$

$$Z = \sqrt{R^2+L^2\omega^2}$$

L = inductance

ω = pulsation

Fig. 7

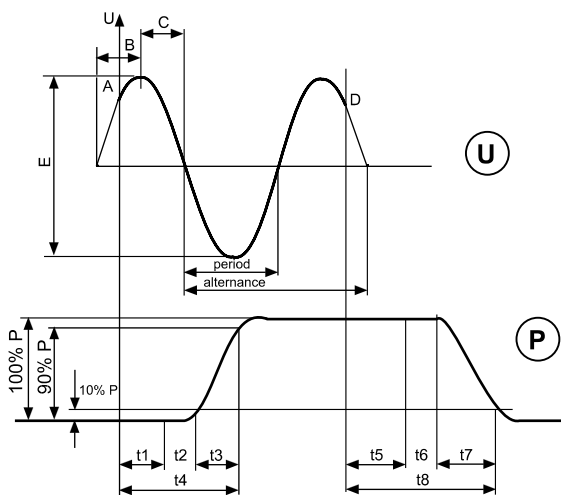
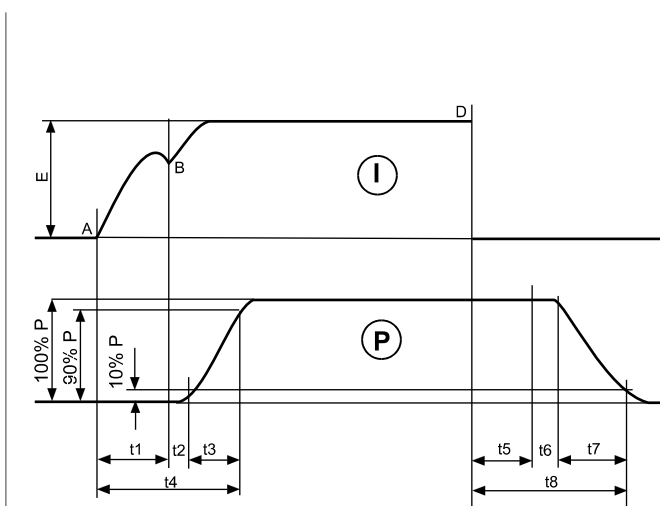

Fig. 7a



Response time

- | | | | |
|---|--------------------|----|--------------------------------|
| U | Voltage | E1 | Plunger |
| I | Current | t2 | Moving parts valve |
| E | Max. voltage | t3 | Increase pressure |
| P | Pressure | t4 | Response time at energizing |
| A | Switch ON | t5 | t5 = t1, t6 = t2 |
| B | Increasing current | t7 | Pressure fall |
| C | Decreasing current | t8 | Response time at de-energizing |
| D | Switch OFF | | |

TECHNICAL INFORMATION

Manual overrides

Our solenoid valves are available with one of the following types of manual overrides :

Rotary type :

Manual override lifts the plunger by eccentric cam. It is available with the following options :

- Slot - made of Brass or Stainless steel, operated by a screw driver, up to 25 bar.
- Plastic - made of Nylon, operated by hand or screw driver, up to 12 bar.
- Knob - made of Brass or Stainless steel, operated by hand, up to 25 bar.

Push Lock :

Manual override lifts the plunger when pushed in, 90° rotation locks it in "ON" position.
Made of Stainless steel. Up to 12 bar.

Push Hold :

Manual override lifts the plunger when pushed in. Made of Stainless steel. Up to 12 bar.

Note: Valves used at pressure higher than 25 bar do not have manual override.

Rotary manual override

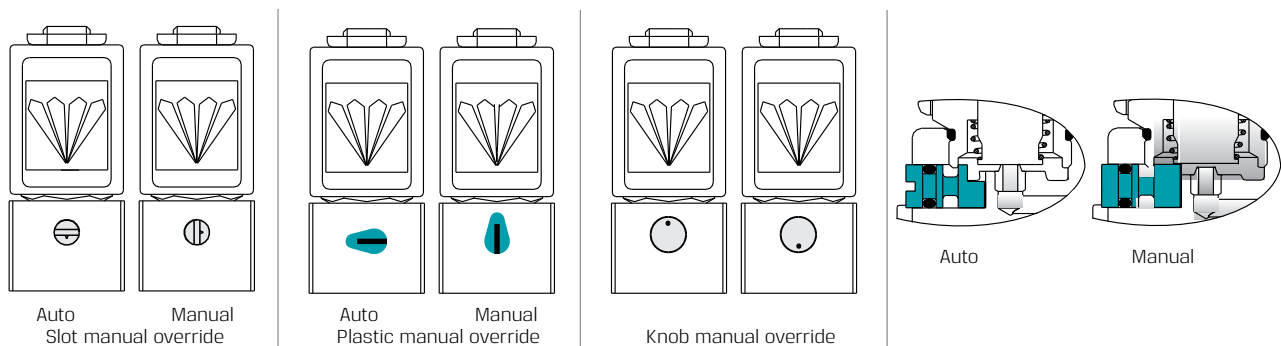

Push Lock manual override

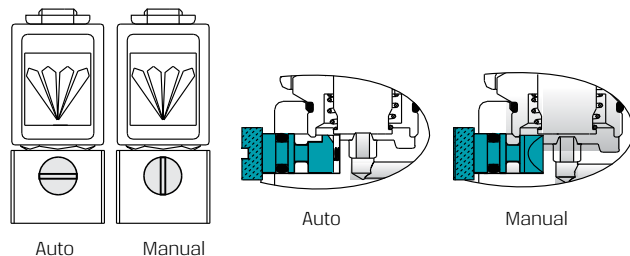

Push Hold Manual Override

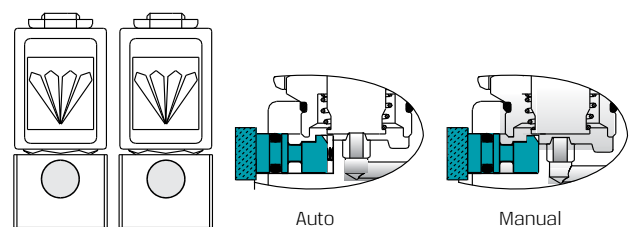

GEM-SOL Special assembly procedures

Valves for oxygen :

- All valve parts degreased to remove all oil. Valve assembled in oil free area with oil free tools and tested with clean air.
- All ports are plugged and the valve is placed in a sealed bag.

Corrosion protection :

- A special film of lubricant is applied to protect the internal parts of the valve from corrosion. This is highly recommended for applications where water drops can remain in the valve.

Reduced noise valves :

- Two and three way valves with bumper to reduce the noise when the solenoid is energized. These valves are for DC only.

Silver shading ring :

- Used on valves where media may attack standard copper rings, but not silver rings.

Helium leak detector :

- We can provide valves and manifolds, tested for leak rates of up to 10^{-9} torr liter per min.

GEM-SOL Elastomer materials

General information

GEM-SOL solenoid valves can be used for many fluid types including acids, gases, solvents etc. To ensure appropriate functioning of the valve, particular care must be taken with the selection of the valve and seals materials. The information below summarizes the elastomers materials used for GEM-SOL valves.

Please contact our technical department for further information.

NBR or BUNA-N

- NBR is a copolymer of butadiene and acrylonitrile. It is the most used elastomer in the seals industry and is the standard elastomer for GEM-SOL valves.
- NBR is suitable for use from -20°C to 85°C. It has benefits over other elastomers with its compression set, tear and abrasion resistance.
- Air, cold water and inert gases are some of the materials NBR is recommended for.

EPDM - Ethylene Propylene Rubber

- EPDM is an elastomer made from ethylene and propylene monomers. It has a wider temperature range than NBR, -40°C to 149°C. Its main disadvantage is that it cannot be used with petroleum oils.
- Water, alcohol and acetone are some of the materials EPDM is recommended for.

Neoprene

- Neoprene is homopolymers of chloroprene. It has a temperature range of -20°C to 85°C. Neoprene is unusual because it is resistant to both oxygen and petroleum.
- Refrigerants, oxygen and petroleum oils are some of the materials Neoprene is recommended for.

FPM (Viton®)

- FPM (Viton®) is a very important elastomer due to its wide compatibility to chemicals. It has a temperature range of -20°C to 180°C. This gives FPM (Viton®) a significant advantage over NBR, but it is still not the ultimate elastomer.
- Diesel oil, gasoline, some acids and trichlorethylene are some of the materials FPM (Viton®) is recommended for.

TECHNICAL INFORMATION

Flow chart for liquids

Kinematic viscosity : Max. 3° Engler

Spec. gravity
 γ (Kg/dm³)

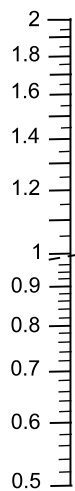

Flow factor
Kv

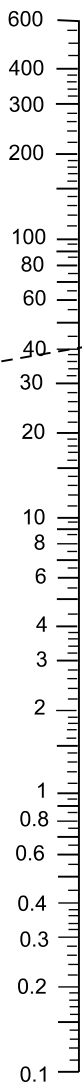

Flow rate
Q (l/min)

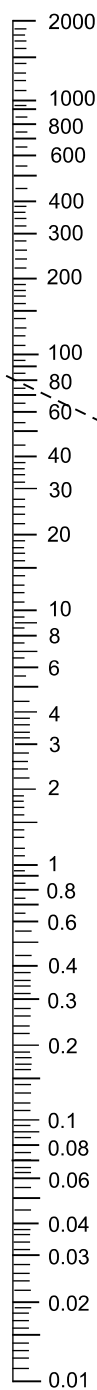

Pressure drop
 Δp (bar)

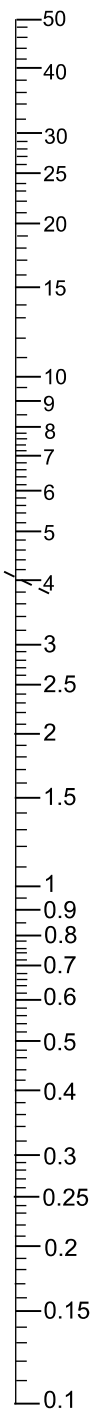

$Q = K_v \sqrt{\frac{\Delta p}{\gamma}}$	$K_v = Q \sqrt{\frac{\gamma}{\Delta p}}$
<p>Q = ? $\gamma = 1$ (water) $K_v = 40$ $\Delta p = 4$ Q = 80 l/min</p>	<p>$K_v = ?$ $\gamma = 1$ (water) $\Delta p = 4$ $Q = 80$ $K_v = 40$</p>

Flow chart for gases

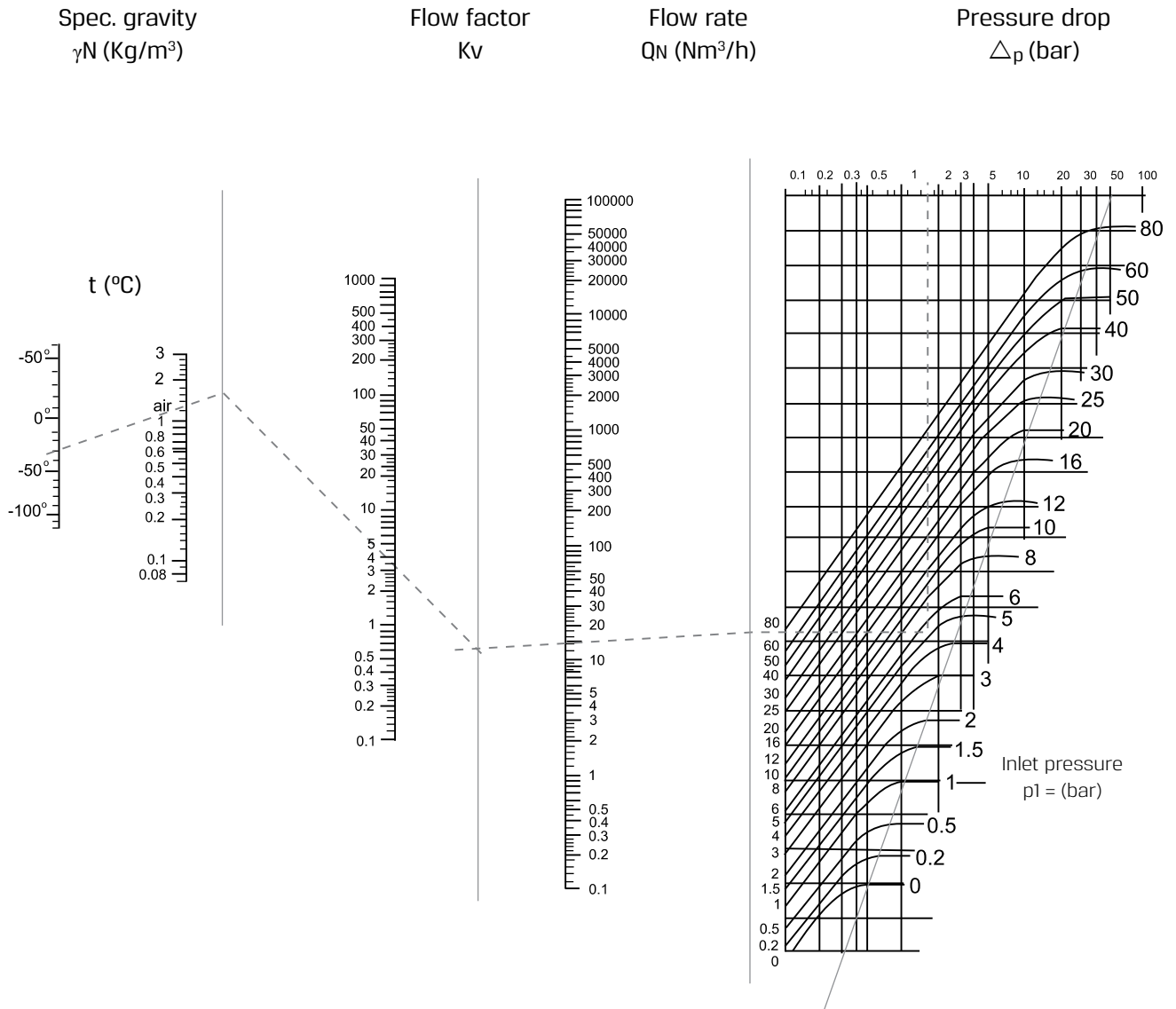

$Q_N = ?$	$K_v = ?$
$t = 25$	$t = 25$
$\gamma_N = 1.3$ (air)	$\gamma_N = 1.3$ (air)
$K_v = 3$	$Q_N = 12$
$p_1 = 5$	$p_1 = 5$
$\Delta p = 1.8$	$\Delta p = 1.8$
$Q_N = 12$ Nm³/h	$K_v = 3$

TECHNICAL INFORMATION

Operation driver for latch coils

Non-direct operation with two switches (or four transistors)

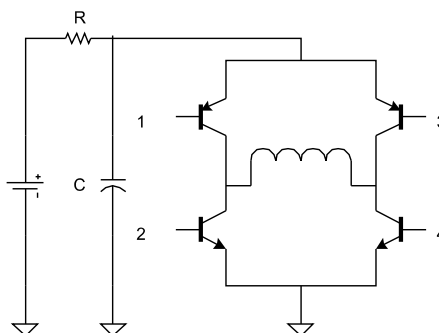
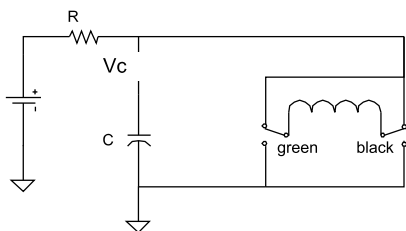

T_{vc} is the time to charge the capacitor. In order to reduce the time, use a similar resistor but never less than 100Ω .

$C = 4700\mu F$

$T_{vc} = 5 \cdot R \cdot C$ [sec]

$t_{on/off} = 30 \div 50$ ms

Non-direct operation with one switch (or transistor)

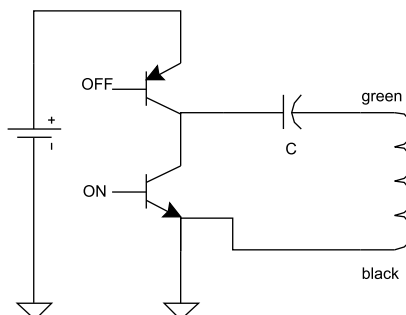
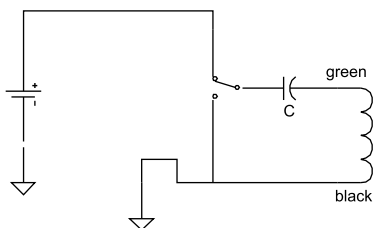

$C = 4700\mu F$

$t_{on/off} = 30 \div 50$ ms

Direct operation

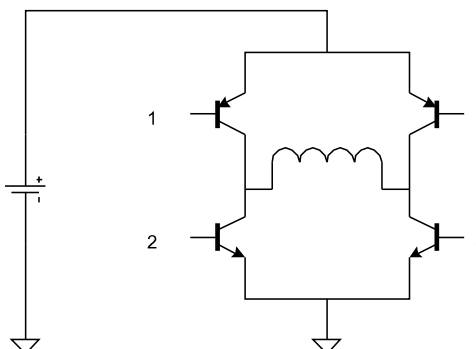
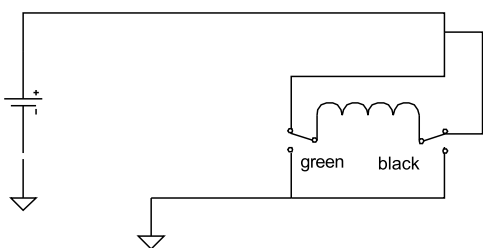

Conduits sizing

GEM-SOL

Wires cross-section selection for distance installation of GEM-SOL solenoids

Solenoid type : GEM-SOL 8W 24V AC					
No. of solenoids	1	2	3	4	Distance
Cross-section [mm ²]	1.0	1.5	2.5	4.0	100m
	1.5	4.0	6.0	6.0	200m
	2.5	6.0			300m
	4.0	6.0			400m
	4.0				500m
	6.0				600m
	6.0				700m
	6.0				800m
					900m
				1000m	

Max. conduits resistance 4Ω

Solenoid type : GEM-SOL 5.5W 24V AC					
No. of solenoids	1	2	3	4	Distance
Cross-section [mm ²]	0.75	1.5	2.5	2.5	100m
	1.5	2.5	4.0	6.0	200m
	2.5	4.0	6.0		300m
	2.5	6.0			400m
	4.0				500m
	4.0				600m
	6.0				700m
	6.0				800m
	6.0				900m
				1000m	

Max. conduits resistance 5Ω

G75

Wires cross-section selection for distance installation of G75 solenoids

Solenoid type : G75 24V AC					
No. of solenoids	1	2	3	4	Distance
Cross-section [mm ²]	0.5	0.5	0.75	1.0	100m
	0.5	1.0	1.5	2.5	200m
	0.75	1.5	2.5	2.5	300m
	1.0	2.5	2.5	4.0	400m
	1.5	2.5	4.0	6.0	500m
	1.5	4.0	4.0	6.0	600m
	2.5	4.0	6.0	6.0	700m
	2.5	4.0	6.0		800m
	2.5	4.0	6.0		900m
	2.5	6.0			1000m

Max. conduits resistance 15Ω

Solenoid type : G75 latch 4Ω					
No. of solenoids	1	2	3	4	Distance
Cross-section [mm ²]	0.75	1.5	1.5	2.5	10m
	1.5	2.5	4.0	6.0	20m
	1.5	4.0	6.0	6.0	30m
	2.5	6.0	6.0		40m
	4.0	6.0			50m
	4.0				60m
	4.0				70m
	6.0				80m
	6.0				90m
	6.0				100m

Max. conduits resistance 0.6Ω

TECHNICAL INFORMATION

Long distance operators charts

LDOS | Long distance operating solenoid

Number of solenoids that operate simultaneously as a function of wire cross-sectional [mm ²] area and distance [mt] from energy source				
Distance in meters from energy source	WIRE CROSS-SECTIONAL AREA [mm ²]			
	0.50	1.00	1.50	2.50
200	12	25	38	65
400	6	12	19	40
600	4	8	12	21
800	3	6	9	16
1,000	2	5	7	13
1,500	1	3	5	9
2,000	1	2	3	6
2,500	1	2	3	5
3,000		1	2	4
3,500		1	2	4
4,000		1	2	3
5,000		1	1	2
6,000			1	2
7,000			1	1
8,000			1	1
9,000				1
10,000				1

Wire's maximum resistance for one solenoid is 175Ω

For further technical information, please refer to product pages in Solenoid Valves | Special purpose section.



LDOS | assembled with GEM-S solenoid

G75-LDO | Long distance operator 2 Way, 3 Way NC, NO

GEM-LDO | Long distance operator 2 Way, 3 Way NC, NO

Number of solenoids that operate simultaneously as a function of wire cross-sectional [mm ²] area and distance [mt] from energy source				
Distance in meters from energy source	WIRE CROSS-SECTIONAL AREA [mm ²]			
	0.50	1.00	1.50	2.50
200	24	56	78	130
400	12	28	39	65
600	8	18	26	43
800	6	14	19	32
1,000	4	11	15	26
1,500	3	7	10	17
2,000	2	5	7	13
2,500	2	4	6	10
3,000	1	3	5	8
3,500	1	3	4	7
4,000	1	2	3	6
5,000	1	2	3	5
6,000		1	2	4
7,000		1	2	3
8,000		1	1	3
9,000		1	1	2
10,000		1	1	2

Wire's maximum resistance for one solenoid is 390Ω

For further technical information, please refer to product page in Solenoid Valves | Special purpose section.



G75-LDO | assembled with G75-A operator & solenoid



GEM-LDO | assembled with GEM-A solenoid

BACCARA WORLDWIDE



Baccara's Worldwide Business

Baccara Israel

Factory & Head Office
Kvutzat Geva, 1891500, Israel
T. +972 4 6535 960 | F. +972 4 6531 445
www.baccara-geva.com

Baccara Australia

15/347 Bay Road
Cheltenham, Victoria 3192, Australia
T. +61 3 9553 4963 | F. +61 3 9553 4965
www.baccarageva.com.au

Baccara USA

4301 South Federal Boulevard
Suite 112, Sheridan, CO 80110
T. +1 720 221 4502
www.baccarausa.com

Baccara South Africa

134 Kuschke Road, Meadowdale,
Johannesburg, South Africa
T. +27 011 453 2223 | F. +27 011 454 6504
www.baccara-geva.com

When
everything connects



Baccara Spain

C/ Marqués de Monteagudo, No. 24, 4ª Derecha
C.P 28028, Madrid, Spain
T. +34 91 3446310 | F. +34 91 3446311
www.baccara-geva.com

Baccara Brazil Representative

BSV Comércio de Válvulas
Rua das Heras 645, Vila Lúcia
São Paulo 03144-080, Brazil
T. +55 11 2338 8906 | F. +55 11 2338 8903
www.bsvcontrol.com.br

Baccara Germany Representative

Mainstr. 38,
50996 Köln, Germany
T. +49 221 956 1503 | F. +49 221 956 1504
www.baccara-geva.com

Baccara Mexico Representative

AMG Instrumentación y Control SA de CV
AV Gustavo Baz 166, Col. La Escuela,
Tlalnepantla, Estado de México - 54090, México
T. +52 55 5662 8120
www.amgvalves.com